



INTEGRAL
POWER //

Volvo Mack Integral Power

Service Manual

Updated: 2/24/2026



Note (Not applicable for hard copies):

1. Phrases in **blue** are “**hyperlinks**” that allow user to jump directly to the respective section. Hold “**ctrl**” and click the link to use.
2. All section titles are “**hyperlinks**” allowing the user to jump back to the top of the document.

Table of Contents

	<u>Page</u>
<u>Service</u>	
• Safety Precautions	4
• Contact Information	6
• Request for Technical Support, Questionnaire	7
• Comments	8
<u>Integral Power System</u>	
• System Summary	9
• System Specifications	9
• Electrical Schematics	10
• A/C Diagnostics Guide	12
<u>Internal/External Components</u>	
• Fuses	16
• Relays	17
• Compressor Controller	18
○ Service Instruction for Ring Terminal Controller and Compressor	20
• Resistor Set	26
• Evaporator Blower	26
• Thermostat	27
• Condenser Fans	28
• Refrigerant Pressure Switch	28
• Compressor	29
○ Thermal Limit Switch	29
• Evaporator Inlet Filter	30
• Low Voltage Disconnect (LVD) Device	31
• Electrolytic Capacitor	31
<u>Refrigerant System</u>	
• Refrigerant Charge Information	32

Table of Contents

Component Servicing

- [Condenser Fan](#) 33
- [Evaporator Blower](#) 34
- [Evaporator Coil](#) 35
- [Thermostat](#) 36
- [Compressor](#) 37
- [Compressor Controller](#) 38
- [Pressure Switch](#) 39
- [Condenser Coil](#) 40
- [Other Serviceable Components](#) 41

Operation Guide

- [Operating Instructions](#) 42

Service

Disclaimer:

Attention!

Before proceeding with any diagnostics, please read the manual thoroughly and, if needed, contact Bergstrom support (Contact Info [HERE](#)). Modifying or servicing the unit could void the warranty.

Warning!

The technical information provided in this service guide is intended for use by properly trained HVAC service personnel, who can ensure a safe and properly operating system. It is assumed that the user of this guide is trained and experienced in basic refrigeration principles, in addition to being familiar with Bergstrom systems. Technicians who repair or service motor vehicle A/C systems must be certified by Section 609 (MACS) approved by the EPA.

Before any air conditioning service is started, it is the technician's responsibility to determine what type of refrigerant is contained in the system. Component marking and/or service port peculiarities are good places to start to identify the contents.

Bergstrom advises that the usual precautions associated with servicing a motor vehicle be exercised when servicing the HVAC system and assumes no liability regarding vehicle damage or personal injury. Additionally, Federal and any Local regulations regarding the handling and use of refrigerants should be always complied with.

NOTES:

TECHNICAL SUPPORT IS PROVIDED TO CERTIFIED TECHNICIANS ONLY.

THE AIR CONDITIONING SYSTEM CONTAINS REFRIGERANT R134A or 1234YF, UNDER HIGH PRESSURE, AND SHOULD BE SERVICED BY ONLY QUALIFIED PERSONNEL.

REPAIRS THAT ALTER THE DESIGN OF THE BERGSTROM SYSTEM, INCLUDING USE OF NON-BERGSTROM SUPPLIED PARTS, WILL VOID THE WARRANTY AND ANY BERGSTROM LIABILITY FOR THE HVAC SYSTEM.

THE BERGSTROM HVAC SYSTEM SHOULD BE SERVICED BY A FULLY TRAINED AND ENVIRONMENTALLY LICENSED TECHNICIAN. FAILURE TO AGREE TO ALL STATEMENTS COULD RESULT IN SERIOUS INJURIES, FINES AND POSSIBLE VOIDING OF ANY WARRANTIES.

TECHNICIANS ARE RESPONSIBLE FOR VERIFYING ALL TRUCK BATTERIES AND AUXILIARY SYSTEM BATTERIES ARE IN GOOD CONDITION AND ARE PROPERLY CHARGED. DO NOT PROCEED WITH ANY DIAGNOSTICS WITHOUT CHECKED BATTERIES AND CONNECTIONS.

Service

Safety Precautions & Warnings

Servicing Refrigerant Systems:

1. Always wear the proper protective eyewear and clothing before working on any refrigeration system. Remember, refrigerant in the air conditioning system can reach pressures of over 500 PSI – if one of those lines bursts while you're working on the system, it can cause serious injury. If refrigerant gets in your eye, it can freeze your eyeball, causing permanent damage or blindness.
2. Always wear work gloves whenever you're working with condensers or evaporators. The aluminum edges are sharp and can cause serious cuts.
3. Always stay clear of the belts and fan blade and be careful revving the engine on a vehicle with a flex fan – damaged blades have been known to come flying off without a moment's warning.
4. Always use a DOT-approved tank for storing used and recycled refrigerants. Look for the Department of Transportation stamp: DOT 4BW or DOT 4BA.
5. Always provide plenty of ventilation when using any electrical testing, recycling, or recovery equipment. Avoid breathing any refrigerant vapor, lubricant vapor, or mist. Exposure to these (particularly PAG oil mist) may irritate your eyes, nose, and throat.
6. Always follow the instructions for your recycling equipment; failure to follow those directions could end up causing personal injury or damaging your equipment. Never perform any maintenance or service on your recycling equipment while the unit is plugged in (unless directed to do so) or without first consulting with authorized service personnel. Removing internal fittings and filters can release pressurized refrigerant. Use care and always wear appropriate safety wear.
7. Never use compressed air to leak test or pressure test an R-134a/1234yf system or service equipment. Under certain conditions, pressurized mixtures of R-134a/1234yf and air can be combustible. Always follow the proper procedures to prevent any safety hazards. In addition, shop air injects moisture into the system, and a pressure surge could damage the evaporator.
8. Microprocessors and computers are susceptible to damage from electrostatic discharge. Always use a static strap when working with these components and always take the necessary precautions to prevent damage to electronic components.

Note: To prevent cross contamination between refrigerants, verify that the A/C system has the correct label and unique service fittings designed for R134a/1234yf refrigerant. If you're ever in doubt, check the system with a refrigerant identifier.

Service

Contact Information



2390 Blackhawk Road
Rockford, IL 61109
USA

Contact	Phone	E-Mail
Technical Support	866 204 8570	producttechsupport@bergstrominc.com
Customer Service	800 499 6849	customerservice@bergstrominc.com
Sales	800 499 6849	vgontero@bergstrominc.com
Parts	800 499 6849	parts@bergstrominc.com
Technical Support (International)	+49 511 86679681	technicalassistance@dirna.bergstrominc.com

Main Website

bergstrominc.com/us/

NOTE: If you are looking for installation instructions, refer to the installation manual. It can be found here:

<https://bergstrominc.com/us/manuals-and-support-installation-manuals/>

Approved Manufacturers Website

Exide Technologies – www.exide.com

East Penn Manufacturing (DEKA) -
<https://www.eastpenmanufacturing.com/products/deka-batteries/>

Odyssey Batteries – www.odysseybattery.com

Trojan – www.trojanbattery.com

Service

Request for Technical Support Questionnaire

DESCRIPTION OF COMPLAINT:

DEALER:

CONTACT/TECH: _____ PHONE #:

CHASSIS: _____ MODEL YR: _____ MODEL:

VEHICLE MANUFACTURER: _____

PRESSURE GAUGE READINGS:

LOW _____ PSIG @ HIGH BLOWER SPEED

HIGH _____ PSIG @ HIGH BLOWER SPEED

AIR TEMPERATURE & HUMIDITY READINGS:

HUMIDITY LEVEL: _____ %RH

RECIRCULATION INLET AIR TEMPERATURE: _____ °F

DISCHARGE AIR TEMPERATURE (VENT CLOSEST TO BASE UNIT): _____ °F

SUBTRACT THE TWO AIR TEMPERATURES = _____ °F DIFFERENTIAL

Integral Power System

Electrical Schematics

12 VDC

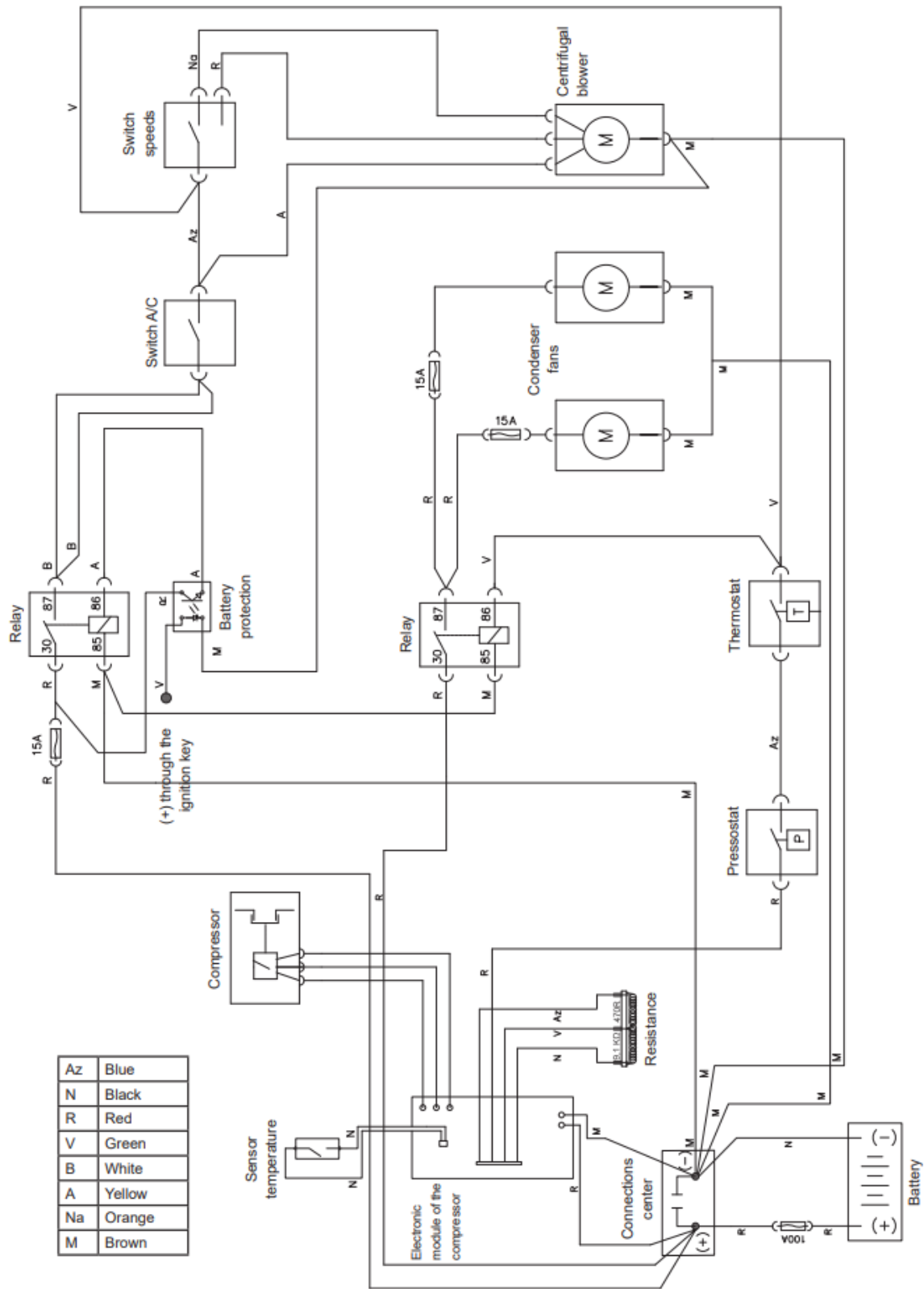

Integral Power System

24 VDC

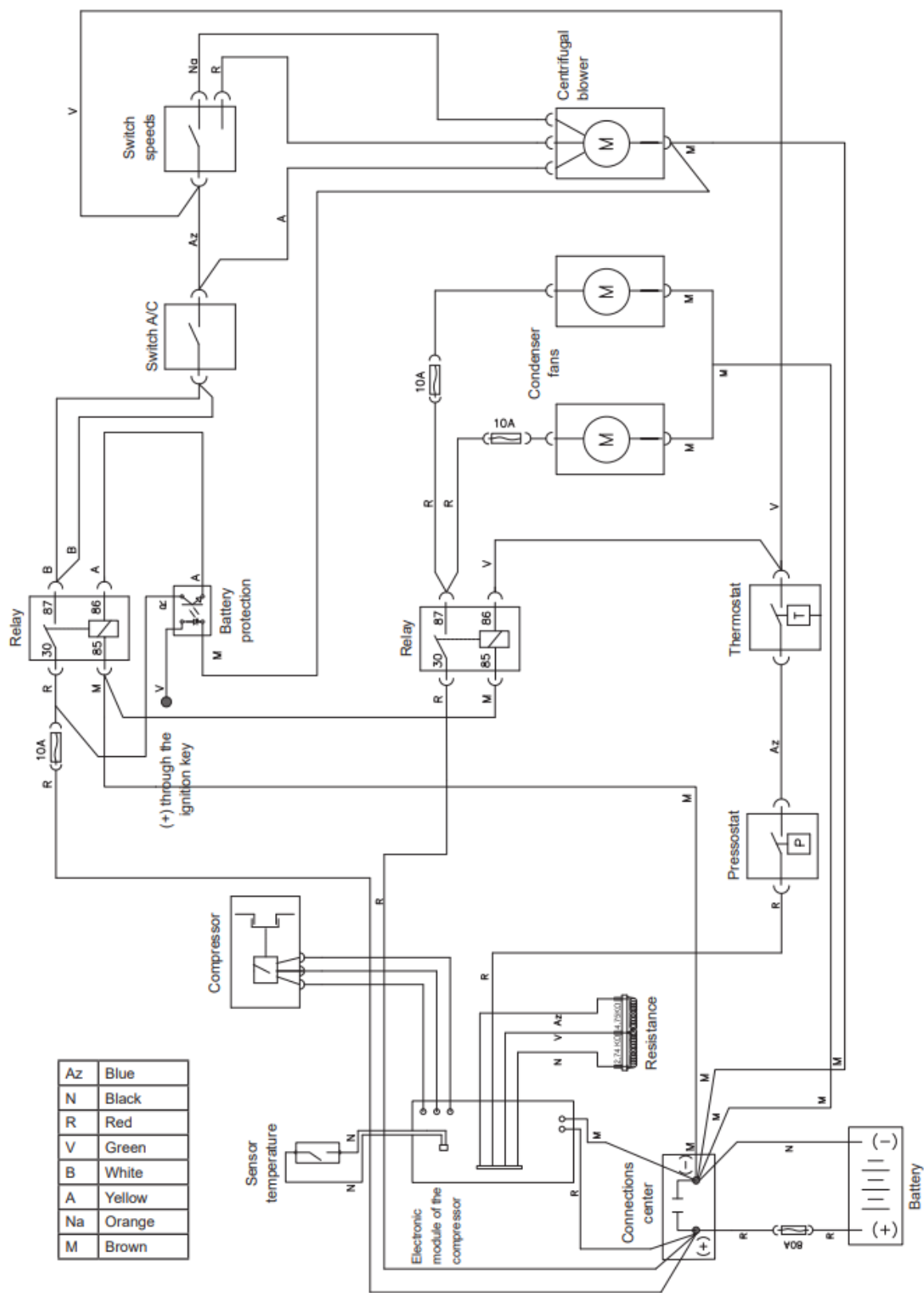

Integral Power System

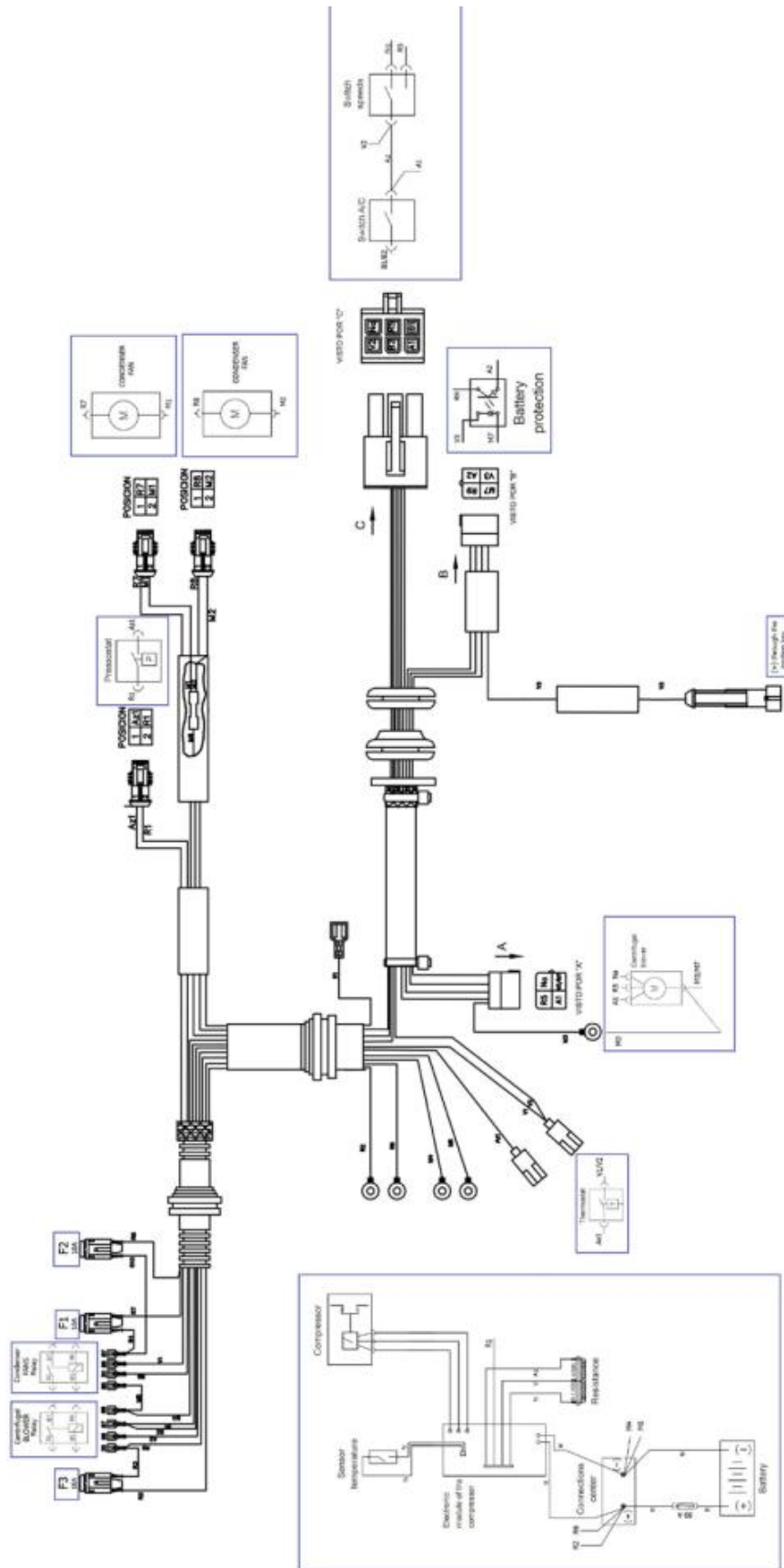

Integral Power System

A/C Diagnostics Guide

Problem	Possible Cause	Corrective Action
Unit Completely Inoperative	Loose connection	Confirm all connections are tight, including ground lugs, and terminals crimped on wires and battery cables.
	No power available at unit	Check all power sources for voltage.
	Blown fuse or fuses	Test all fuses . Refer to wiring .
	Check voltage path to the unit and control	Check for 24V through the 80-amp main fuse and F3 10-amp control fuse to control panel. Check connection to ignition key point.
	Defective control panel switches	Test control panel switches.
	Broken wire or defective wire harness	Inspect wiring harness and all ground connections.
Unit runs – but does not blow cold air	Airflow blockage	Clear any blockage from recirculation grill or louvers. Also check condenser inlet and outlet for restriction (outside truck).
	Compressor controller connections / defective compressor	Confirm all wire harness connectors are connected. Test compressor controller .
	Condenser fan or pressure switch defective	Test pressure switch and condenser fan .
	Thermostat	Test thermostat .
	Compressor thermal switch	Test compressor thermal switch .
	Evaporator blower defective	Test evaporator blower .
	Resistor set	Test resistor set .
	Loss of charge (refrigerant system is serviceable)	If all tests check OK, a loss of refrigerant charge may have occurred. Refer to refrigerant charge information .

Integral Power System

	Poor electrical connection	Check electrical connections.
	Condenser fan inoperative	Test condenser fan .
	Airflow blockage causing high pressure or freeze condition	Check for restricted airflow outside truck at condenser inlet and outlet and at louvers and recirculation grill. Check pressure switch , thermostat , and/or thermal limit switch on compressor.
Unit blows cold air, but low airflow	Duct work	Verify all ducts are connected, sealed, and secure.
	Airflow restriction	Check for airflow at louvers and recirculation grill.
	Evaporator blower motor inoperative	Test evaporator blower and control panel switches .
Unit is noisy or vibrates	Evaporator blower motor	Test evaporator blower .
	Condenser fan motor	Test condenser fan .
	Compressor rubber mounts	Check the compressor rubber mounting features.
	Compressor internal	If rubber mounts are acceptable and compressor vibrates excessively, contact Bergstrom support .
Unit runs correctly, but less than expected run time	Ground terminal	Inspect and tighten all power and ground connections.
	Weak or uncharged batteries	Check battery condition and state of charge. Check LED status in LVD.
	High amp draw	Use DC ammeter to check amperage when running. Excessive amperage could signal compressor or internal component issue. Unit current ranges from 40-65 A depending on settings and conditions.
	Battery LVD system	Check LVD device and harness.

Internal/External Components

Fuses

F1 – 15 Amp

Provides short circuit protection for condenser fan #1. Location – on control center.

F2 – 15 Amp

Provides short circuit protection for condenser fan #2. Location – on control center.

F3 – 15 Amp

Provides short circuit protection for the evaporator blower and control panel. Location – on control center.

F4 – 100 Amp (only 12V)

Provides short circuit protection for the unit. Location – on the power wire.

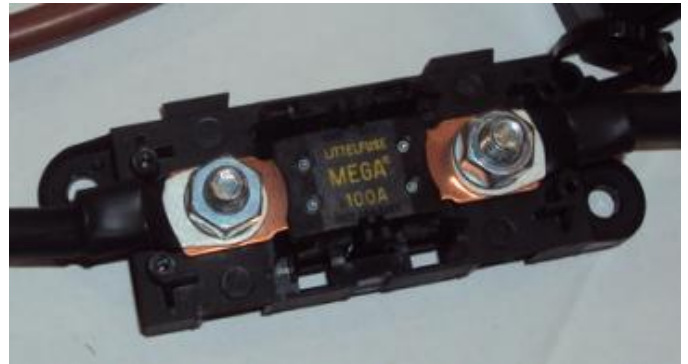
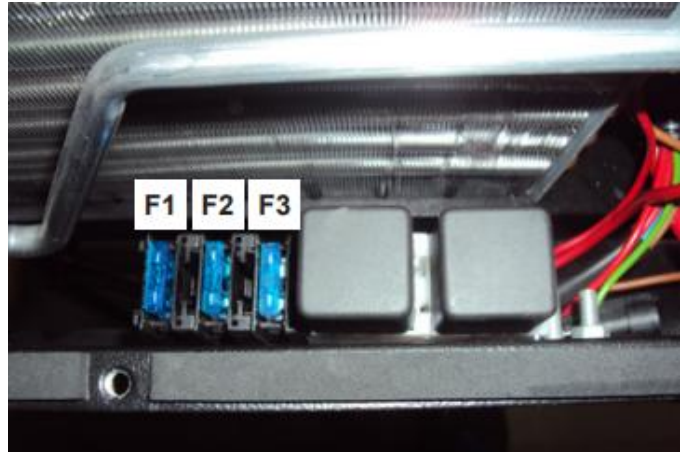

Internal/External Components

Relays

R1

Controls the 24V voltage to the blower.
12V to latch this relay. Location – on control center.

R2

Controls the voltage to the condenser fans.

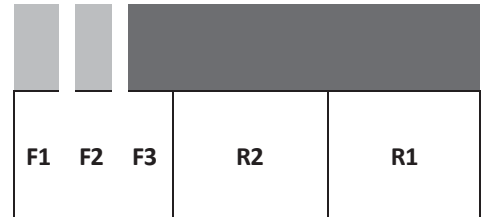
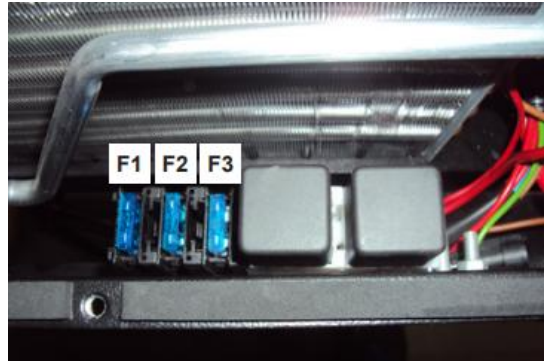

Testing

With relay unplugged, confirm there is 24 V on pin 30 (use diagram to identify which blade terminal is connected to pin 30). If no voltage, check [fuses](#), [wiring](#), and/or battery connections.

With relay unplugged, confirm there is 12 V (R1) or 24 V (R2) on pin 86 (use diagram to identify which blade terminal is connected to pin 86). If no voltage, check ignition wiring (R1) or A/C switch wiring (R2). Refer to [wiring](#).

Now, with relay unplugged, check across terminals 85 and 86 of the relay, using an Ohmmeter. You should have approx. 80 to 100 ohms, measuring the resistance through the relay coil. If you do not have this value, replace the relay.

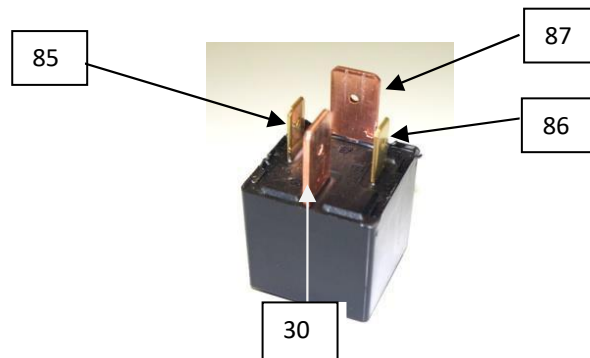

Internal/External Components

Compressor Controller

This device controls the output voltage to the variable speed compressor. It is located under the metallic cover.



Testing

You must remove the plastic cover and metallic cover to access the controller.

Do not attempt to test the controller or compressor until you have ruled out all other possibilities.

When you turn the Integral Power unit on, if all safety devices are ok, such as the High/Low pressure switch, thermostat, and the compressor thermal limit switch: the compressor, evaporator blower, and condenser fan will begin to operate.

Use the following steps to check the compressor controller:

1. With the A/C switch off, verify you have 24V on the power and ground studs of the compressor controller. If not, check [fuse F4](#), [wiring](#), and/or battery connections.
2. Turn the A/C switch ON. If all signals are correct and the safety controls: thermal limit on compressor, High/ Low pressure switch, and thermostat are ok; you should have 24 V on the compressor enable signal (pin 2 of the 6-pin connector).

When this signal has 24 V, the three wires connected to the compressor terminals: A – Blue, B – Orange and C – Yellow. (ABC – BOY), should produce a pulse voltage to the compressor.

3. If the compressor does not operate, disconnect the three wires from the compressor. You will have to remove plastic cap from the top of compressor.

Using a voltmeter, check each wire: positive on (blue, orange, or yellow) and negative to battery ground. If you do not have a 4.7 – 10.9 volts pulse voltage out on each wire, replace the controller. Pulse voltage means the controller will cycle to each colored wire. You should see the voltage blinking in and out continuously.

If you do have a 4.7 – 10.9 V pulse voltage out and the compressor does not run; you have a defective compressor.

Refer to the service instruction below for servicing the phase harness on the compressor and compressor controller.

Internal/External Components

Attention: Removing the phase harness for testing.

Operating the system for troubleshooting purposes with the phase harness disconnected can result in a locked-out system.

With no active fault codes, the controller should always attempt to start the compressor up to 10 times in a period of approx. 2 minutes; even when the phase harness is disconnected. If the controller does not see the compressor start after 10 attempts, it will time out and stop sending voltage to the compressor. The controller will remain in locked out mode until power is cycled.

Please make sure the time does not expire during the test procedure. If necessary, cycling the power switch off and back on will reset the controller.

Note: The compressor could take up to 2 minutes to start up after the power switch has been cycled.

When reconnecting the three wires you must connect blue to A, orange to B, and yellow to C. Wires must always be connected in this order and torqued to 12-14 inlbs (+/- .89 inlb).

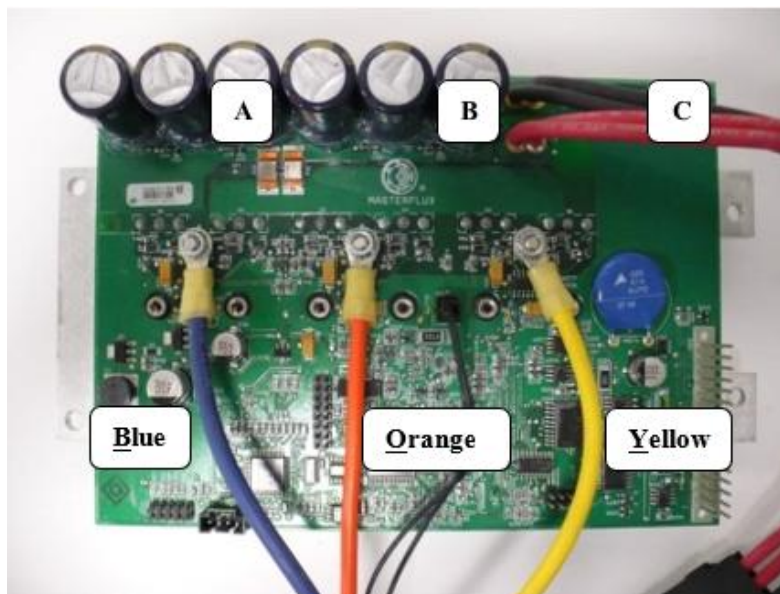

Internal/External Components

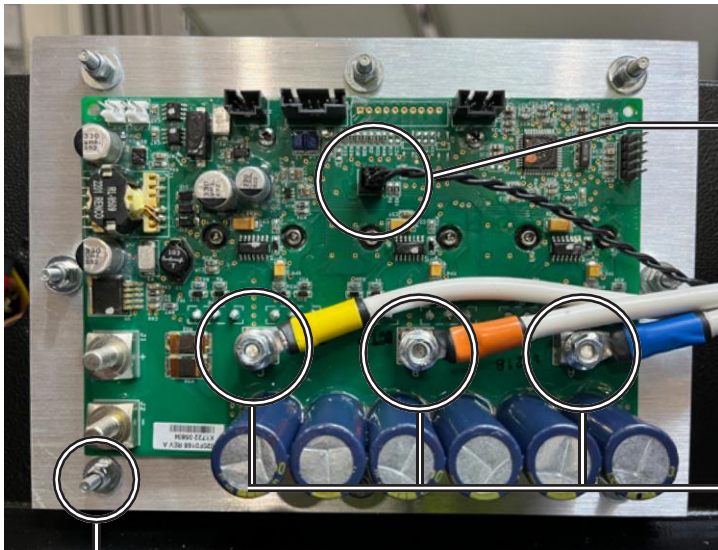

5. UNPLUG 2-PIN CONNECTOR FROM PCB & REMOVE PHASE HARNESS.

6. REMOVE (3) NUTS AND (3) WASHERS HOLDING PHASE HARNESS RING TERMINALS TO PCB.

(8) NUTS AND (8) CONTROLLER FIXING WASHERS.



Internal/External Components

7. SLIDE (3) RING TERMINALS OF PHASE HARNESS OVER THREADED POSTS OF PCB.

CAUTION: ALIGN EACH COLORED WIRE TO SPECIFIC THREADED POST IDENTIFIED ONLY.

SECURE WITH 3 NUTS REMOVED IN STEP 7.
TORQUE TO 20+/- 2 In-Lbs (Toque D)

CAUTION: USE ONLY THE TORQUE VALUE LISTED WHEN INSTALLING PHASE HARNESS TO PCB!

8. PLUG 2-PIN CONNECTOR OF NEW HARNESS INTO PCB.

(POSITIVE, RED WIRE)

(NEGATIVE, BLACK WIRE)

YELLOW WIRE ("C")

ORANGE WIRE ("B")

BLUE WIRE ("A")

ORIENT RING TERMINALS AND ROUTE HARNESS OUT OF COVER AS SHOWN.

Internal/External Components

9. SLIDE BLACK AND RED RING TERMINALS OF UNIT HARNESS OVER THREADED POSTS OF PCB.

WARNING: ALIGN BLACK AND RED WIRES TO SPECIFIC THREADED POST IDENTIFIED ONLY. REVERSING THE POLARITY CAN CAUSE A HAZARDOUS CONDITION.

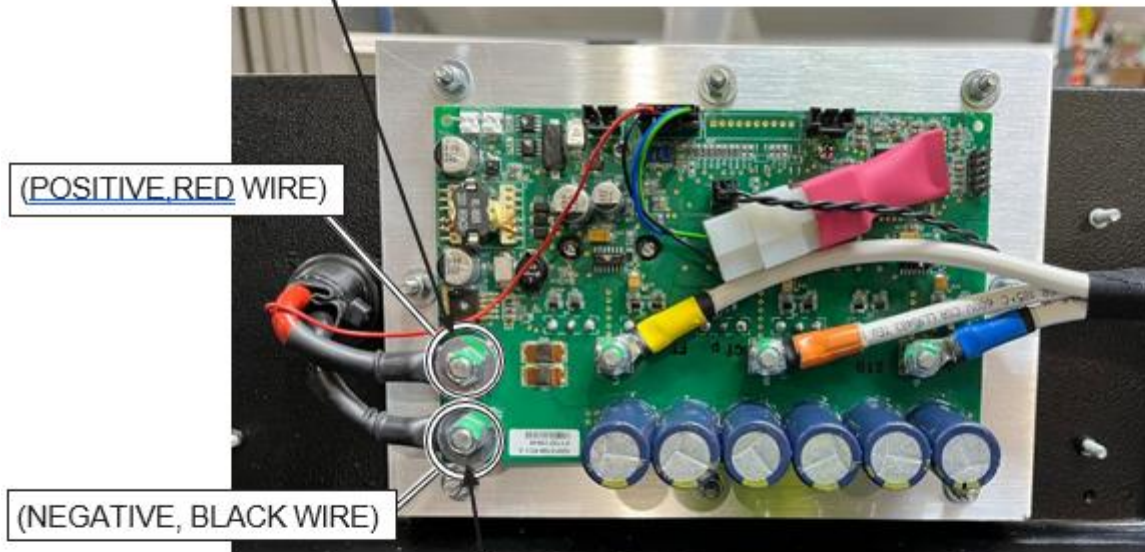

10. SECURE WITH (2) NEW, LARGE NUTS PROVIDED ONLY.
TORQUE TO **38 +/- 2 In-Lbs** (Torque E)

CAUTION: USE ONLY NEW HARDWARE AND THE TORQUE VALUE SPECIFIED.

CAUTION: DO NOT ALLOW THE RING TERMINALS OF THE BLACK AND RED WIRES TO BE IN CONTACT AFTER ROUTING WIRES AND REPLACING COVERS.

Internal/External Components

Ring Terminal Compressor ONLY

Id	Description	Torque In-Lbs
A	Screws of three phases harness compressor	30 +/- 2
B	Upper screws of compressor controller cover	29 +/- 2
C	Side nuts of compressor controller cover	16 +/- 2
D	Nuts of the terminals of the three phases harness controller	20 +/- 2
E	Nuts of the power harness	38 +/- 2

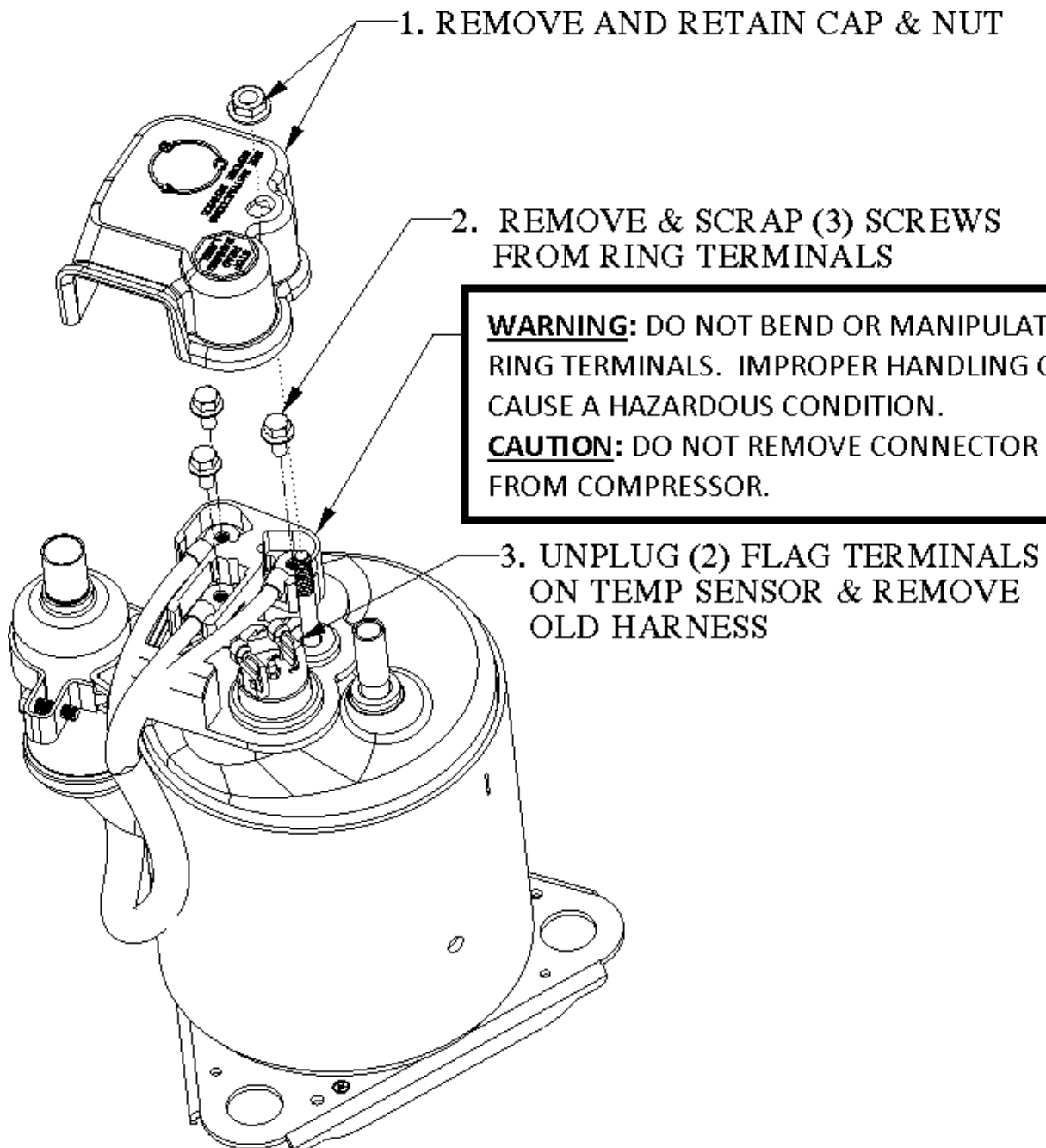

Internal/External Components

4. ALIGN (3) RING TERMINALS OF NEW HARNESS TO COMPRESSOR CONNECTOR.

CAUTION: ALIGN EACH COLORED WIRE TO SPECIFIED POSITION ONLY.

5. ATTACH RING TERMINALS WITH (3) NEW SCREWS PROVIDED ONLY. TORQUE TO 20 ± 2 INCH-LBS

WARNING: USE ONLY NEW HARDWARE AND THE TORQUE VALUE SPECIFIED. IMPROPER HANDLING CAN CAUSE A HAZARDOUS CONDITION.

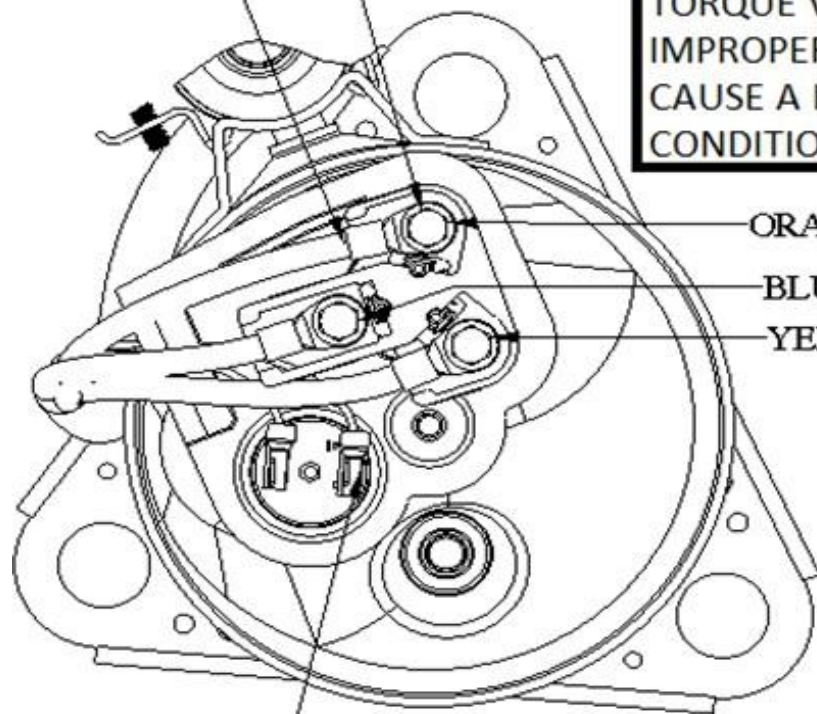

ORANGE WIRE

BLUE WIRE

YELLOW WIRE

6. PLUG IN (2) FLAG TERMINALS OF NEW HARNESS AT TEMP SENSOR

7. REPLACE CAP & NUT

Internal/External Components

Resistor Set

Resistive voltage divider to set the speed of the compressor.

Location – inside the unit, under the metal cover.



Testing

To determine the compressor speed, the compressor controller uses a voltage input. The compressor controller has a 5V output that is used to power the two-resistor set pictured. The resulting value of the divisor is connected to the compressor controller speed input. The value must be 4.75 +/- 0.2 V and can be measured with a voltmeter.

An ohmmeter can be used to check the value of the two 1% tolerance resistors

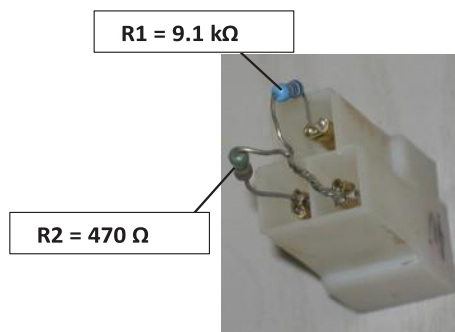

Evaporator Blower

The blower pulls air through the evaporator coil and blows conditioned air into the interior of the cabin.

Location – inside the unit, under the evaporator cover.

Testing on next page....

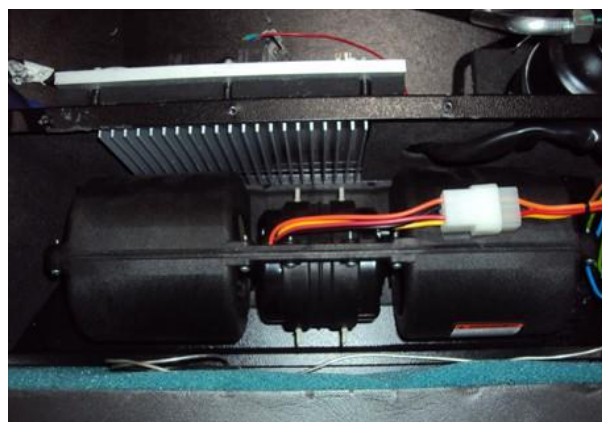

Internal/External Components

Testing

First do a visual inspection of all blower parts.

The blower speed switch controls the evaporator blower speed.

Turn the system ON. You should have 24V at the input side of the blower speed switch. If not, check [fuse F3](#) and [relay R1](#). If yes, verify you have 24V on the selected blower speed out wire.

Disconnect the blower assembly connector. Verify you have 24V on the selected blower speed wire on the harness side of the connector. If yes and blower isn't running, replace blower assembly.

Using a DC ammeter, you can check the amperage draw of the blower. Normal amps will range from 5 – 10 A.

Thermostat

This sensor checks the evaporator outlet air temperature and open it's switch to disable the compressor if necessary.

Location – inside the unit, under the evaporator cover.

The thermostat can be adjusted by turning the regulating pin until the lower part of the regulating cam is aligned with the mark on the thermostat box.

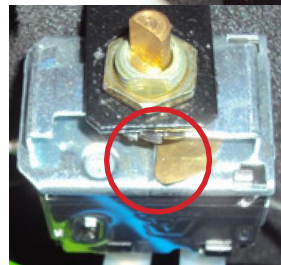

Testing

You must remove the top cover and the evaporator cover to access.

The thermostat is a temperature switch. To verify the condition, you will need a meter capable of checking continuity.

If a freeze condition occurs, the unit will stop the compressor (open circuit in the switch). If the freeze condition leaves, the compressor will restart and the unit will continue to run (closed circuit in the switch).

Turn the system ON and test the continuity of the switch under normal conditions. If you do not have continuity, replace the thermostat.

Internal/External Components

Condenser Fans

These two fans draw air from the truck and push it through the condenser coil to cool the refrigerant flowing through the system. The hot air is exhausted into the outer atmosphere.

Location – in the cover.



Testing

First do a visual inspection of all fan parts.

Turn the system ON. You should have 24V across the terminals on each condenser fan connector. If you do and the fan(s) do (does) not run, replace fan(s). If not, check [fuses F1 and F2](#) as well as [relay R2](#).

Using a DC ammeter, you can check the amperage draw of the fan. Normal value is around 6A.

Refrigerant High-Pressure Switch

This normally closed threaded pressure switch will open and prevent the operation of the compressor due to high or low internal high side pressure.

Location – in the refrigerant gas circuit.



Testing

You must remove top cover to access the switch.

The switch is normally closed unless a pressure situation has occurred. When the unit is off for a few minutes, test continuity between the two terminals.

If there is an issue with the refrigerant charge level, this may cause the switch to open. Refer to [refrigerant charge information](#).

	CUTT IN Bar	CUTT OFF Bar
H/P	19	25
L/P	2.1	2

Internal/External Components

Compressor

This component is part of the hermetically sealed refrigeration system.



Testing

Refer to [system and compressor controller](#) and [service instructions for ring terminal compressors](#).

Testing (Rubber Mounts)

Visual inspection of the compressor rubber mounts may be necessary if excessive vibration is present. Check for loose mounting nuts. If mounting nuts and captive studs are ok, vibration could be from the internal aspects of the compressor.

Thermal Limit Switch

This is a normally closed (auto reset) switch to protect the compressor from high temperature.



Testing

You must remove the top cover and the plastic shield on top of the compressor to access the switch. This device is a normally closed switch. If the compressor gets too hot, the thermal limit switch will open, and the compressor will stop. Checking with a meter you should always have continuity between the two terminals when it is cool.

Internal/External Components

Evaporator Inlet Filter

This filter protects the evaporator coil from dust and debris. It is washable and should be serviced every other month by washing dust and debris off with warm water. In environments with pets or dusty environments the filter may need more frequent washing. Failure to do so will affect the performance of the unit and could lead to drain tube clogging.



Note: Odors from luggage compartment may be vented back into the sleeper cab.

When necessary, "Check Filter" indicator will notify you that the filter must be cleaned or changed. To reset "Check Filter": at screen 1 press and hold enter button for 3 seconds.

Internal/External Components

Low Voltage Disconnect (LVD) Device

This device monitors the batteries voltage, and determines if that voltage is high enough for the unit to function.

Green LED light indicates enough voltage in the battery.

Red LED light indicates low battery charge and prevents the use of the unit.

Location – behind the front panel.

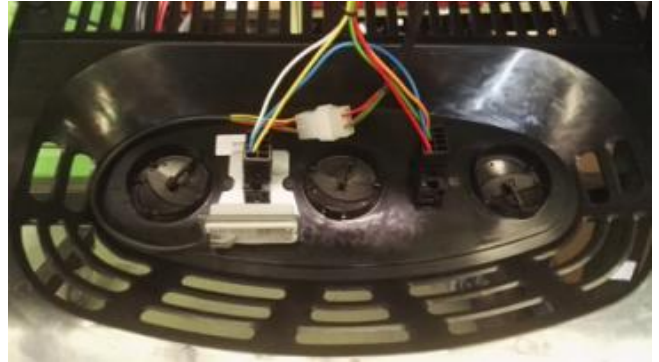

Testing

When the truck starting battery falls below 11.5 V for 20 seconds, the LVD will disengage the relay. Once the truck battery voltage is above 13.5 V, the LVD will send an engage signal to the relay, allowing the unit to function.

Before testing the LVD, unplug the device for at least 1 minute to reset the system. Then reconnect the LVD and attempt to operate the system. If the system does not operate, continue with the below testing.

Verify the battery voltage is above 13.5 V. The LVD should show a green LED light and R2 should be engaged. If not, the LVD is defective and needs to be replaced.

With the battery voltage under 11.5 V, the LVD should show a red LED light and R2 should be disengaged. If you do not see the red LED light, the LVD is defective and should be replaced.

Electrolytic Capacitor

This component filters the possible electromagnetic noise in the power wiring.

Location – on the control center.



Refrigerant System

Refrigerant Charge Information

Warning! Before doing any of the work below, be aware of the dangers involved. Working with refrigerant could lead to serious personal injury.

Caution! If the equipment being used adds system refrigerant oil during the evacuation/charging procedure, you must first DISABLE this feature. Follow the instructions furnished with the recovery station, or refrigerant oil injector tool, to disable this feature.

Charge Level for the System: 1100 g (2.43 lbs.) Virgin R134a

Approved Leak Detection Methods

The Integral Power system uses non-conductive compressor oil. Use only polyvinylether (PVE) refrigerant oil in this system. The system should never be recovered to check AC charge. The system does not need any oil added unless refrigerant loop components have been replaced, or the system has been recovered in excess of 4 times. Addition of improper oil types, or too much oil, will cause damage to the compressor.

System starts with 355cc of PVE oil.

Component Servicing

Condenser Fan

Condenser Fan Removal

1. Remove the plastic cover for the unit by removing the 5 T30 screws.

Note: The 2 screws in the rear are longer than the 3 in front.

2. Disconnect the electrical connector for both fans and remove cover (with fans).
3. Remove the 4 Phillips head screws holding the fan to the cover. Remove fan.

Condenser Fan Installation

1. Slide new fan into place and secure with 4 screws. Torque to 16 in. lbs.
2. Move the cover into place and connect both condenser fan electrical connectors.
3. Install plastic cover and secure using 5 screws. Torque to 29 in. lbs.

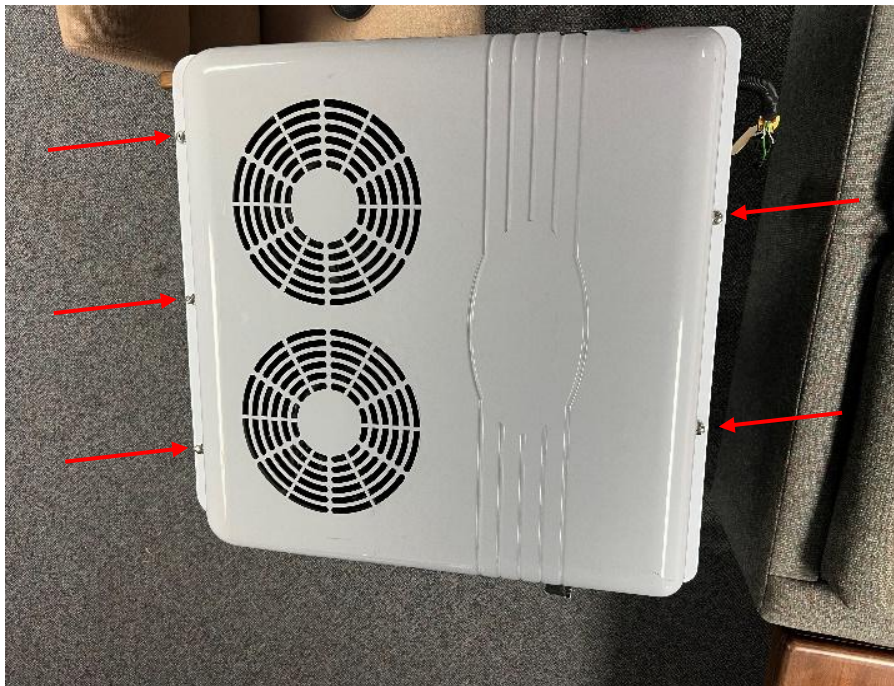

Component Servicing

Evaporator Blower Assembly

Note: A detailed work instruction is available online for replacement of older blower assembly with newer blower assembly + evaporator coil guard.

Blower Removal

1. Remove the plastic cover for the unit by removing the 5 T30 screws.

Note: The 2 screws in the rear are longer than the 3 in front.

2. Disconnect the electrical connector for both condenser fans and remove cover (with fans).
3. Loosen the 4 7mm nuts holding the compressor controller cover.
4. Remove the 9 Phillips head screws for the blower cover and remove cover.
5. Remove the 2 Phillips screws holding the blower assembly to the bottom of the unit.
6. Remove blower electrical connector and remove blower assembly.

Blower Installation

1. Insert new blower assembly into place as shown and connect the electrical connector.
2. Secure the 2 screws holding the assembly to the bottom of the unit. Torque to 29 in. lbs.
3. Secure the blower cover with 9 screws. Torque to 16 in. lbs.
4. Tighten the 4 nuts for the compressor controller cover. Torque to 16 in. lbs.
5. Hold the main cover in place and connect both condenser fan electrical connectors.
6. Install plastic cover and secure with 5 screws. Torque to 29 in. lbs.

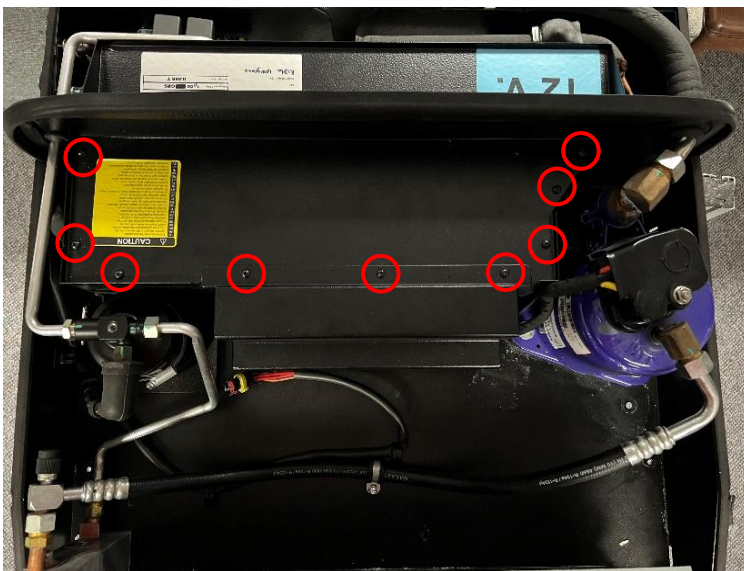

Component Servicing

Evaporator Coil

Evaporator Coil Removal

1. Remove the plastic cover for the unit by removing the 5 T30 screws.

Note: The 2 screws in the rear are longer than the 3 in front.

2. Disconnect the electrical connector for both condenser fans and remove cover (with fans).
3. **Evacuate the system refrigerant.** Refer to the refrigerant machine manufacturing instructions.
4. Loosen the 4 7mm nuts holding the compressor controller cover.
5. Remove the 9 Phillips head screws for the blower cover and remove cover.
6. Using a 10 mm socket with extension, remove the TXV flange and refrigerant connections to the TXV.
7. Temporarily remove the evaporator coil freeze probe.
8. Pull out the coil with TXV.

Evaporator Coil Installation

1. Insert the new coil and TXV into the unit.
2. Insert the evaporator freeze probe into the same location in the new coil as was removed from the old coil.
3. Secure the refrigerant lines to the TXV using the TXV flange plate and screw. Torque to 50 in. lbs.
4. Secure the blower cover with 9 screws. Torque to 16 in. lbs.
5. Tighten the 4 nuts for the compressor controller cover. Torque to 16 in. lbs.
6. Re-charge the system with refrigerant. Refer to [refrigerant charge information](#).
7. Hold the main cover in place and connect both condenser fan electrical connectors.
8. Install plastic cover and secure using 5 screws. Torque to 29 in. lbs.

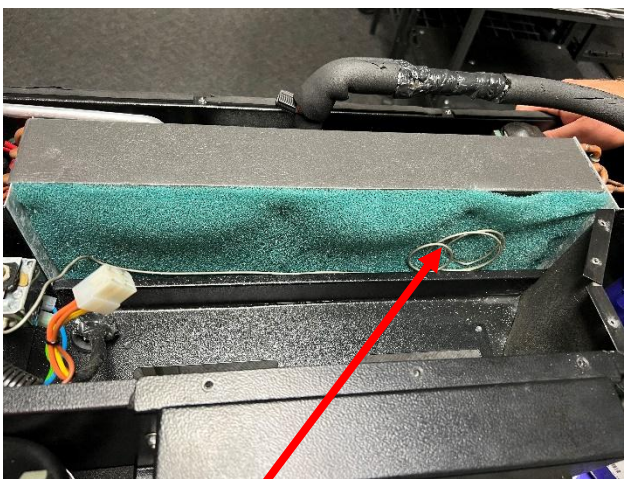

Freeze Probe



TXV Screw

Component Servicing

Thermostat / Freeze Probe

Thermostat Removal

1. Remove the plastic cover for the unit by removing the 5 T30 screws.

Note: The 2 screws in the rear are longer than the 3 in front.

2. Disconnect the electrical connector for both condenser fans and remove cover (with fans).
3. Loosen the 4 7mm nuts holding the compressor controller cover.
4. Remove the 9 Phillips head screws for the blower cover and remove cover.
5. Slowly pull the probe out of the evaporator coil. Note the location of removal.
6. Disconnect the 2 blade terminal connections to the bottom of the thermostat.
7. Remove the tooth lock washer holding the thermostat to the unit bracket. Remove thermostat with probe.

Thermostat Installation

1. Secure the thermostat to the unit bracket with the tooth lock washer. Hand tighten.
2. Slowly insert the new probe into the hole noted in removal.
3. Connect the 2 blade terminal connections to the bottom of the thermostat.
4. Secure the blower cover with 9 screws. Torque to 16 in. lbs.
5. Tighten the 4 nuts for the compressor controller cover. Torque to 16 in. lbs.
6. Hold the main cover in place and connect both condenser fan electrical connectors.
7. Install plastic cover and secure using 5 screws. Torque to 29 in. lbs.



Thermostat



Freeze Probe

Component Servicing

Compressor

Compressor Removal

1. Remove the plastic cover for the unit by removing the 5 T30 screws.

Note: The 2 screws in the rear are longer than the 3 in front.

2. Disconnect the electrical connector for both condenser fans and remove cover (with fans).
3. **Evacuate the system refrigerant.** Refer to the refrigerant machine manufacturing instructions.
4. Remove the refrigerant lines from the compressor using two crescent wrenches.

Note: You must use a backer wrench on the compressor side of the connection to avoid damaging refrigerant lines.

4. Remove the phase harness from the compressor. Refer to the [service instruction for ring terminal compressors](#).
5. Use a 10 mm socket to remove the 3 nuts holding the compressor to the unit floor. Pull out compressor. DO NOT TIP.

Compressor Installation

1. Insert new compressor in the orientation shown and secure with the 3 nuts. Verify each connection has a rubber mount, inner bushing, washer, and nut. Torque to 3.5 ft. lbs.
2. Refer to the [service instruction for ring terminal compressors](#) to connect the phase harness to the compressor.
3. Connect the refrigerant lines to the compressor using two crescent wrenches.

Note: You must use a backer wrench on the compressor side of the connection to avoid damaging refrigerant lines.

4. Re-charge the system with refrigerant. Refer to [refrigerant charge information](#).
5. Hold the main cover in place and connect both condenser fan electrical connectors.
6. Install plastic cover and secure using 5 screws. Torque to 29 in. lbs.

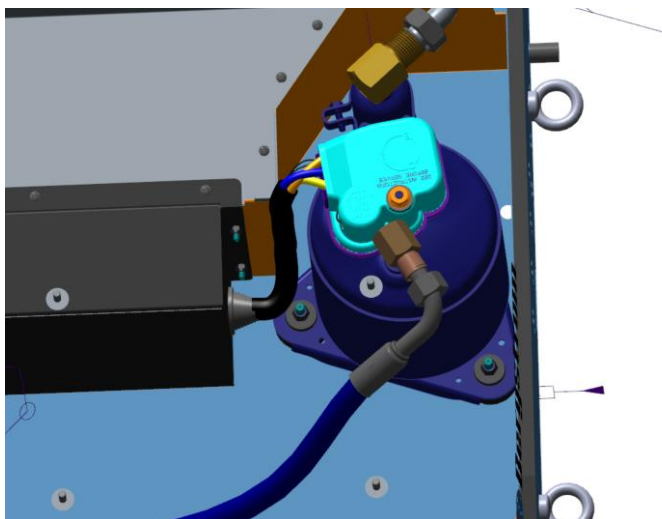

Component Servicing

Compressor Controller

Compressor Controller Removal

1. Remove the plastic cover for the unit by removing the 5 T30 screws.

Note: The 2 screws in the rear are longer than the 3 in front.

2. Disconnect the electrical connector for both condenser fans and remove cover (with fans).
3. Remove the 4 7 mm nuts holding the compressor controller cover.
4. Temporarily remove the compressor controller interface connector.
5. Remove the phase harness from the compressor controller. Refer to the [service instruction for compressor controllers](#).
6. Remove the power and ground connections from the compressor controller by removing the 2 nuts with a 10 mm socket.
7. Remove the 8 nuts holding the controller to the unit with a 7 mm socket. Remove controller.

Compressor Controller Installation

1. Insert the new controller in the orientation shown and secure with 8 nuts with washers. Torque to 16 in. lbs.
2. Connect the power and ground wires using the 2 nuts with washers. Verify red on positive (+). Torque to 36 in. lbs.
3. Connect the phase harness to the compressor controller using the [service instruction for compressor controllers](#).
4. Connect the controller interface connector.
5. Secure the compressor controller cover with the 4 nuts. Torque to 16 in. lbs.
6. Hold the main cover in place and connect both condenser fan electrical connectors.
7. Install plastic cover and secure using 5 screws. Torque to 29 in. lbs.

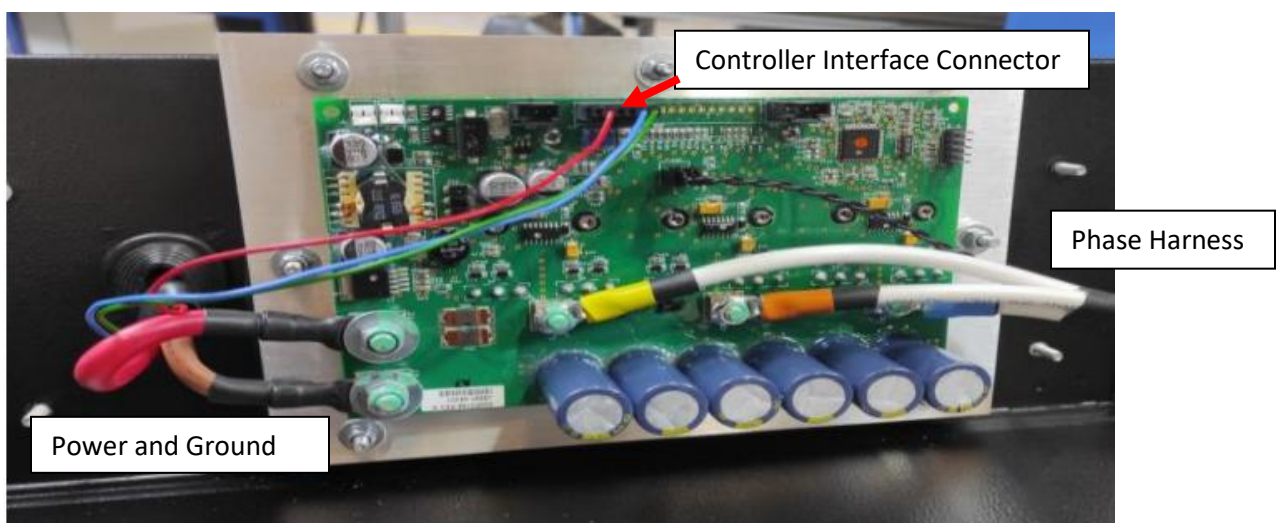

Component Servicing

Pressure Switch

Pressure Switch Removal

1. Remove the plastic cover for the unit by removing the 5 T30 screws.

Note: The 2 screws in the rear are longer than the 3 in front.

2. Disconnect the electrical connector for both condenser fans and remove cover (with fans).
3. Disconnect the pressure switch electrical connector.
4. **Evacuate the system refrigerant.** Refer to the refrigerant machine manufacturing instructions.
5. Use a crescent wrench to remove the pressure switch from the receiver drier. Use a backer wrench on the receiver drier to avoid damaging components.

Pressure Switch Installation

1. Screw in the new pressure switch. Use a backer wrench on the receiver drier to avoid damaging components. Torque to 7.3 ft. lbs.
2. Connect the pressure switch electrical connector.
3. Re-charge the system with refrigerant. Refer to [refrigerant charge information](#).
4. Hold the main cover in place and connect both condenser fan electrical connectors.
5. Install plastic cover and secure using 5 screws. Torque to 29 in. lbs.

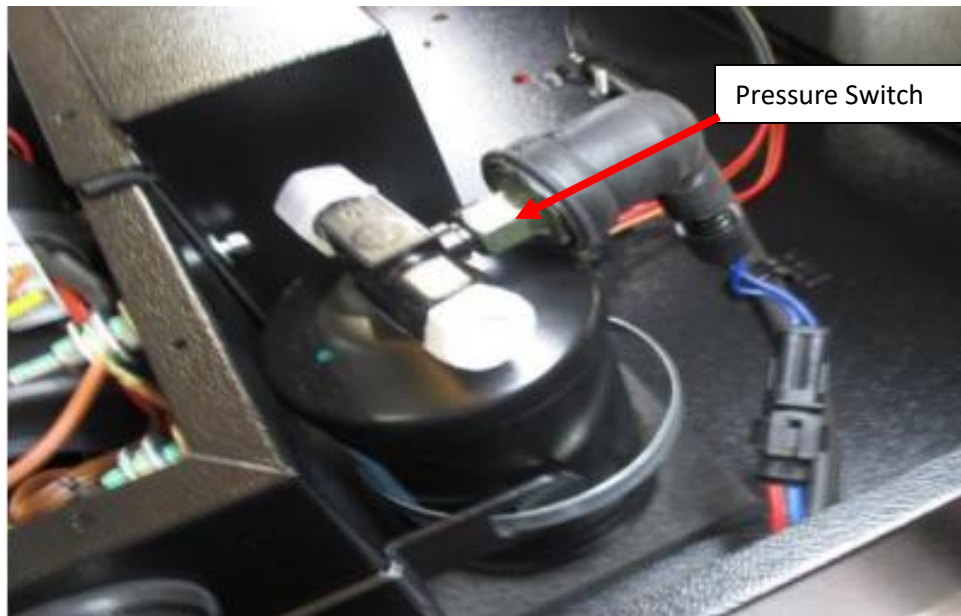

Component Servicing

Condenser Coil

Condenser Coil Removal

1. Remove the plastic cover for the unit by removing the 5 T30 screws.

Note: The 2 screws in the rear are longer than the 3 in front.

2. Disconnect the electrical connector for both condenser fans and remove cover (with fans).
3. **Evacuate the system refrigerant.** Refer to the refrigerant machine manufacturing instructions.
4. Remove the refrigerant lines from the condenser coil using two crescent wrenches.

Note: You must use a backer wrench on the condenser side of the connection to avoid damaging refrigerant lines.

5. Remove the 4 nuts holding the coil to the bottom of the unit with a 10 mm socket. Remove coil.

Condenser Coil Installation

1. Place the new coil into place and secure with 4 nuts. Torque to 3.5 ft. lbs.
2. Secure the refrigerant lines to the condenser coil using two crescent wrenches. Torque to 11 ft. lbs.

Note: You must use a backer wrench on the condenser side of the connection to avoid damaging refrigerant lines.

3. Re-charge the system with refrigerant. Refer to [refrigerant charge information](#).
4. Hold the main cover in place and connect both condenser fan electrical connectors.
5. Install plastic cover and secure using 5 screws. Torque to 29 in. lbs.

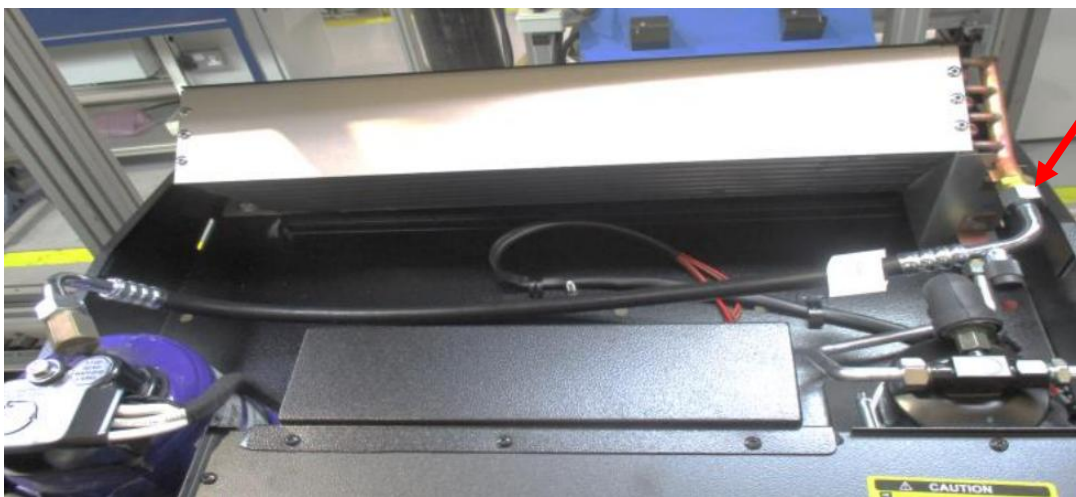

Component Servicing

Other Serviceable Components

Receiver Drier

Wire Harness

TXV

Various Covers

Filter

Various Refrigerant Lines

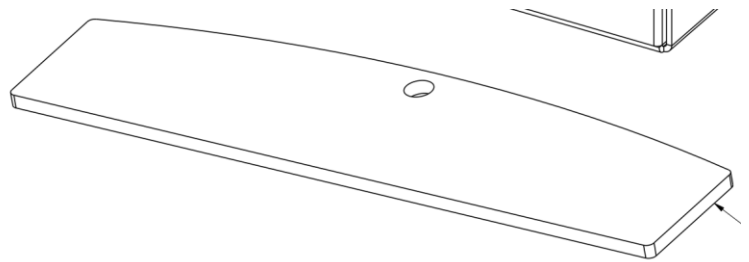
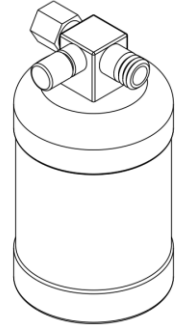

Operating Instructions

Operating Instructions



1. ON / OFF switch. 1st blower speed.

Activating the switch starts the system. On activation, the 1st blower speed, compressor, and condenser fan will operate.



2. 2nd and 3rd blower speed selection.

Activating the switch (2 positions) selects the 2nd and 3rd blower speeds.

